

The economic value of CAD systems in structural design and construction

A modelling approach

Reynold A. Chandansingh

Logisterion Automatisering, Rotterdam, formerly Delft University of Technology, Dept. of Civil Engineering, Section for Concrete Structures.

A modelling approach is provided for the analysis of cost-effects of CAD systems. It aims to support strategic management of CAD systems in structural design and construction. The approach is based on the production digraph model of production processes, and the value-added model of information commodities. It has been verified in three case-studies: two concerning the cost-effects in the structural design process at engineering consultants, and one concerning the cost-effects in the production process at a reinforcement-subcontractor. The results of two cases are provided, together with conclusions based on all three case-studies.

Keywords: Modelling, information commodity, production digraph, cost-effects, CAD systems, structural design, construction

1 Introduction

1.1 Significance of CAD systems

Nowadays information technology (IT) is considered to be one of the key-technologies in construction, and information is considered to be a key resource within business activities. In the strategy of all major companies IT plays an important role. Betts (1992) describes how major international companies, such as the M.W. Kellogg Co. and Taisei Co., compete through introduction and integration of information systems. Furthermore, Tatum (1990) indicates how Computer Aided Engineering (CAE) systems can be deployed to improve construction planning, operations, and quality.

Computer Aided Design (CAD)¹ systems offer construction companies the possibility to meet challenges placed on them by developments in society and construction itself. CAD systems are computer-based information systems which aid the process of creation, analysis, modification, and representation of designs. Related IT-concepts are Computer Aided Manufacturing (CAM), Computer Aided Engineering (CAE), and Product Data Interchange (PDI). Integration of these concepts in design and construction is referred to as Computer Integrated Construction (CIC).

¹ By a CAD system is meant not only the software itself, but the infrastructure (consisting of hardware, network, etc.) as well. The infrastructure is considered to be an essential part, since the CAD system cannot be used without it.

Chandansingh & Vos (1991) performed a survey among the larger engineering consultants in the Netherlands, all members of the ONRI², concerning the use of CAD systems for reinforced concrete detailing. It showed that several CAD systems are used, which differ with respect to their capabilities, limitations, structure, and functions. On top of that, the systems are implemented and used in quite different ways and intensities.

Secondly, it was found that implementation and use of CAD systems were mainly (information) technology-driven. Decisions concerning use were rarely based on anything other than the desire to gain experience with this rather new technology. In most cases costs³ and benefits were not evaluated properly to support decisionmaking concerning use.

In the few cases that an evaluation was performed, the method of the payback period was used. However, it seemed hard to determine the benefits of a CAD system, in contrast with the costs. In addition the consultants were unable to relate the benefits to the specific features of the CAD system, although they stated clearly that the benefits depend on these features. Benefits were described in qualitative terms mainly, which were found to be inappropriate for proper decision-making.

For strategic management of implementation and use of CAD systems (and information systems in general) current methods are not good enough. Management requires methods for analyses of the effects of CAD systems on business processes, which will support proper evaluation of CAD systems. An analytic framework is needed for both ex-post (descriptive) and ex-ante (predictive) analyses of the effects of the several CAD systems.

1.2 *Aim and scope*

This paper describes an analytical framework, which facilitates systematic analyses of the effects of CAD systems on design and construction. The framework aims at supporting the selection of CAD systems and exploitation of their use. It enables management to (re-) direct the use of CAD systems.

The framework is restricted to the market value (or economic value) of CAD systems. The market value is determined by the supply value and the demand value. The supply value may be estimated by the minimal costs which are involved in purchase or development of the CAD system. The demand value may be estimated by the maximum amount of money the user is willing to pay for the CAD system. The framework aims to determine an upper-bound for the demand value of the CAD system, expressed in cost-reductions resulting from use of the system.

The effects of CAD systems on a process depend on two variables: the type of CAD system under consideration and the nature of the process. Dealing with these two variables, the framework consists of two concepts. On the one hand, the "value-added model of information commodities", which facilitates a classification of CAD systems, based on identification of value-adding attributes.

² The Association of Consulting Engineers of the Netherlands.

³ Here is referred to the generic meaning of the term "costs", which includes both financial and non-financial aspects.

On the other hand, the “production digraph model”, which facilitates classification of processes, according to their activities and costs-structure.

The framework has been applied in the domain of structural design and construction of reinforced concrete (RC) structures. A major part of this process deals with the design and production of reinforcement. In the context of this paper we refer to the production of reinforcement when speaking of construction processes.

1.3 Outline of the paper

The next two sections (2 and 3) of this paper describe the “value-added model of information commodities” and the “production digraph model”. Sections 4 and 5 describe two different case-studies based on this framework. The first analyzed the cost-effects of CAD systems in structural design. The second analyzed the cost-effects of CAD systems (through an intermediate product called “WUF-diskette”) in production of reinforcement. Applications of the framework are described by Chandansingh (1993a, 1993b, 1995) as well. Finally, section 6 provides conclusions, based on the PhD-research (see Chandansingh, 1995).

2 Value-added model of information commodities

2.1 Definition of information

The value-added model of information commodity is based on a definition of information in relation to its role in processes. Because information is used to make decisions and control processes, Mowshowitz (1992a) defined information as: “the ability of a goal-seeking system to decide and control”. Decide means: choosing one alternative among several that may be executed in pursuit of a well-defined objective. Control means: the ordering of actions that may be executed in pursuit of a well-defined objective. A goal-seeking system is a system whose actions are designed to achieve a well-defined objective.

2.2 Definition of information commodities

Mowshowitz (1992a) defines an information commodity as “a type of commodity which furnishes information (or the ability to decide and control)”. To be a commodity an entity must meet two factors: appropriability and valuability. Appropriability is the capacity of being owned. Valuability is the capacity of being assigned a market value in some standard unit. To be an information commodity, the commodity must furnish information in some sense.

Examples of information commodities are information-related products, systems, and services. A distinction can be made between passive and active information commodities. This distinction is based on processing power. Books, magazines, and catalogues are examples of passive information commodities. Computer systems and on-line databases are examples of active information commodities, because they are capable of inferring new facts from items currently in the file.

2.3 *Value-added model of information commodities*

The value of an information commodity derives from its capacity to furnish information. Its market value depends not only on the information content of the commodity, but on other factors as well. These other factors are related to carrying and accessing characteristics of information commodities. Based on this observation, Mowshowitz (1992b) developed the value-added model of information commodities. This model consists of the factors that determine the capacity of information commodities to furnish information. The value adding dimensions may be interpreted as the means for providing access to information.

The value-added model of information commodities consists of five major value adding dimensions, which can be used to classify information commodities:

1. kernel, consisting of:
 - a. procedural information,
 - b. declarative information,
2. storage,
3. processing,
4. distribution,
5. presentation.

2.4 *Value adding dimensions of CAD systems*

2.4.1 *Are CAD systems information commodities*

CAD systems are information commodities (of a certain type), since they meet the two specified requirements. Each token (license) of a CAD system has a unique owner, who has purchased it. The same token can not be owned by any other owner, so a token of a system meets the requirement of appropriability. As (individual components of) CAD systems are traded, it is possible to determine both supply and demand value. So, the second requirement of valuability is met as well.

A CAD system consists of three components: the computer hardware, the operating system and the CAD system software. Each individual component may be viewed as an information commodity. Differences between CAD systems can occur in each individual component. However, the most important differences refer to the value adding dimensions of the CAD system software. These are the main determinants of the value of the CAD system.

2.4.2 *Computer hardware*

The most important value adding dimensions of the computer hardware are storage (e.g. capacity, speed of access, reliability), processing (e.g. speed of processing), distribution (e.g. speed of the channel), and presentation (e.g. size and resolution of display, and lay-out of keys). Computer hardware includes a kernel as well, which is not included in this discussion, since it is roughly the same for all the competing hardware.

Chandansingh (1995) describes the value adding dimensions of two computer hardware configurations: a stand-alone personal computer and a personal computer in a network. The computer hard-

ware is important, since it determines the speed of response to the user. However, these value adding dimensions are not provided here, since cost-effects are not very sensitive to (differences in) the computer hardware.

2.4.3 Operating system

The operating system has one significant value adding dimension, namely the kernel, with procedural information as the most important component. The procedural information consists of routines for controlling the processor, hard-disk, RAM, and software (e.g. CAD system software). Several operating systems are used today (e.g. MS-Dos, MS-Windows, Unix, etc.). The most widely used operating system is MS-Dos, but the use of MS-Windows is increasing. It is very difficult to relate cost-effects to the operating systems used.

Table 1. Value adding dimensions of CAD software.

Value Adding Dimensions	CAD software B1	CAD software B2
Kernel		
- procedural information (routines for:)	1. Modelling of graphical entities; input, edit (copy, move, group, etc.), and presentation. 2. Determining measures from the model. 3. Re-scaling of graphical entities and symbols. 4. Managing project-database and files. 11. Numbering of symbols and generating lists.	1. Modelling of graphical entities; input, edit (copy, move, group, etc.), and presentation. 2. Determining measures from the model. 3. Re-scaling of graphical entities and symbols. 4. Managing project-database and files. 11. Numbering of symbols and generating lists. 12. Modelling of prefab structural elements (including generating material lists, annotating measures, and determining add. information).
- declarative information (libraries with:)	5. Settings (defaults) for model-layers. 6. Symbols, shading, text, etc. 7. Graphical symbols (very limited). 8. Project information stored in project-files. 9. Graphical symbols of (standard) construction details and reinforcement.	5. Settings (defaults) for model-layers. 6. Symbols, shading, text, etc. 7. Graphical symbols (very limited). 8. Project information stored in project-files. 9. Graphical symbols of (standard) construction details and reinforcement. 10. Predefined models of prefab structural elements (including related features).
Storage		
Processing		
Distribution		
Presentation		

2.4.4 CAD system software

Cost-effects of a CAD system depend on the value adding dimensions of the CAD system software mainly. The main value adding dimension is the kernel. CAD system software furnishes procedural information in the form of routines for the processing of declarative information. In addition, the CAD system software provides databases with declarative information, and possibilities to create and maintain databases.

Table 1 provides the value adding dimensions of two types of CAD system software: CAD system B1 and CAD system B2. From this table it can be seen that system B2 consists of system B1, extended with routines and databases. This is often the case as CAD systems are tailored for a specific domain by extending it with routines and databases. These specific CAD systems are often referred to as CAD-applications.

3 The production digraph model

3.1 Definition

A formal structural model is required to analyze the cost-effects of information commodities in production processes. Mowshowitz (1992c) introduced the production digraph model, based on graph theory, to model costs of a process. A production digraph is a collection of interrelated activities, which facilitate the modelling of costs by assigning weights to nodes and arcs. The resulting weighted production digraph allows analyses of cost-effects.

For a detailed discussion of the production digraph model, see Mowshowitz (1992c). The graph theoretic terminology is based on Harary (1969). Figure 1 summarizes the terminology and the basic components of the production digraph.

Definition (Mowshowitz, 1992c):

P is a production digraph,

if: $P = P(V, E, a, z, c, w)$, where:

V is a set of vertices or nodes;

E is a set of directed edges or arcs joining distinct pairs of nodes

a is an unique node (the *source*) of indegree zero;

z is an unique node (the *sink*) of outdegree zero;

c is a function mapping V to the non-negative reals;

w is a function mapping E to the non-negative reals;

and: $O(x) = c(x) + I(x)$ for all nodes x in P , where:

$O(x)$ is the output of x , $O(x) = \sum w(xi)$ for all nodes i ,

(i.e. the sum of weights of the arcs directed from node x);

$c(x)$ is the weight assigned to node x ;

$I(x)$ is the input of x , $I(x) = \sum w(ix)$ for all nodes i ,

(i.e. the sum of weights of the edges directed to node x);

and: P is *acyclic*.

The nodes of a production digraph represent the activities of a production process. An arc from node x to node y signifies a dependence-relation: the activity corresponding to node y requires input from the activity corresponding to node x in order to perform its function. The boundaries of the production process being modelled are set by an initiating and a terminating node: the source and the sink respectively.

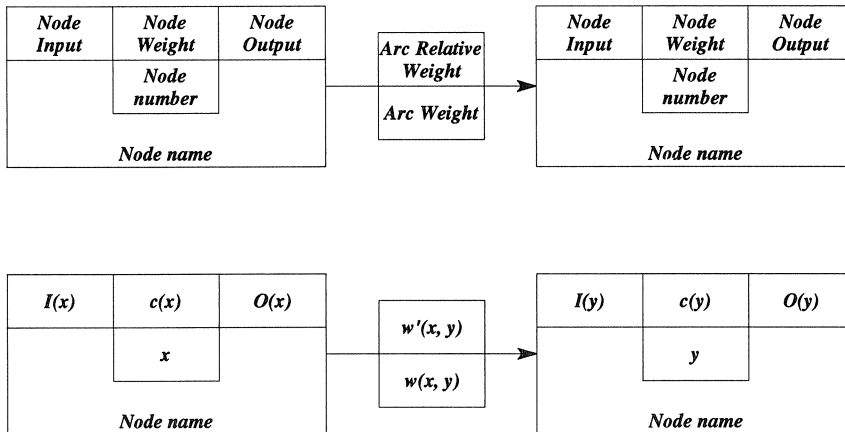

Fig. 1. Terminology and basic components of the production digraph.

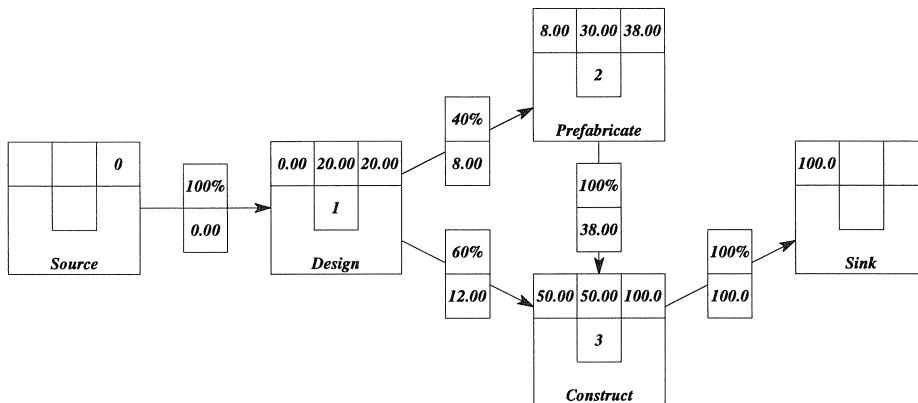

Fig. 2. Production digraph of simplified building process.

The function c assigns a weight to each node, representing the property being modelled. In this case such a node-weight represents the costs of the processing performed within the activities on its input. The function w assigns a weight to each arc (directed edge) in the production digraph, which reflects the cost-relations. For example arc-weight $w(x, y)$ is the portion of the costs of the output of x that is allocated to y .

Figure 2 illustrates the use of the production digraph model. Suppose it represents a simplified example of the interacting activities and the costs of a building process. Such a representation is useful to analyze the cost-effects. For example, to analyze the cost-effects resulting from the use of specific software for design and detailing of prefab elements of concrete structures. Figure 3 shows the cost-effects due to the use of such software.

3.2 Effects on the production digraph

Five types of effects can be modelled in a production digraph, either separately or in combination, to represent changes in the costs of a production process. The first effect refers to change in the processing within an activity of the process, resulting in change of the activity's costs, while cost-relations between activities remain the same. This change is modelled as an effect on the node-weight (corresponding to the activity), while the arcs are not altered. However, often the arc-weights following on the altered node-weights have to be re-adjusted to the new node-weight.

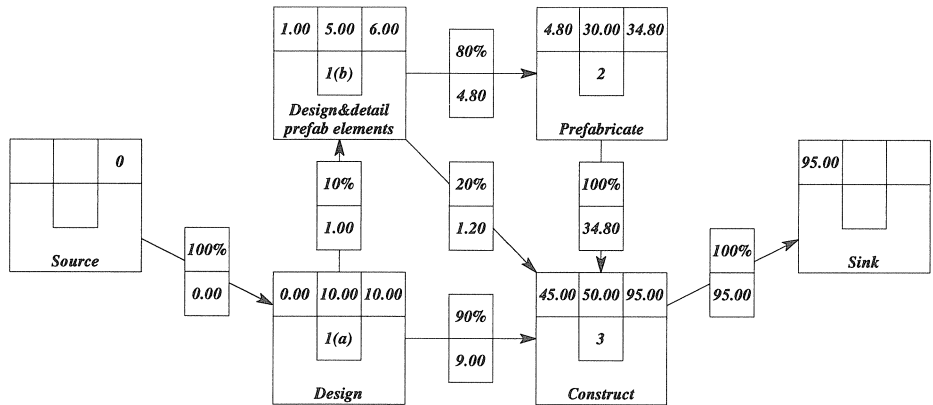

Fig. 3. Changes in the production digraph of simplified building process.

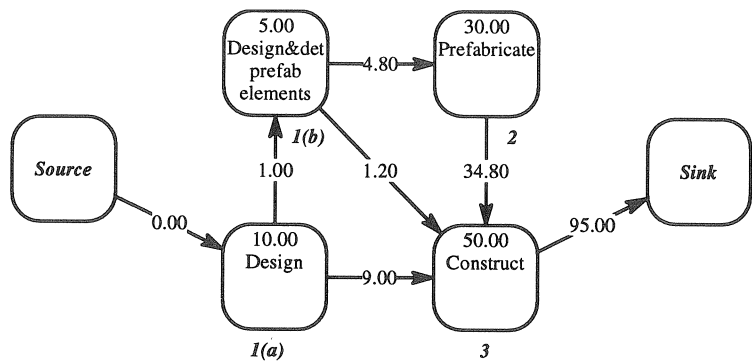
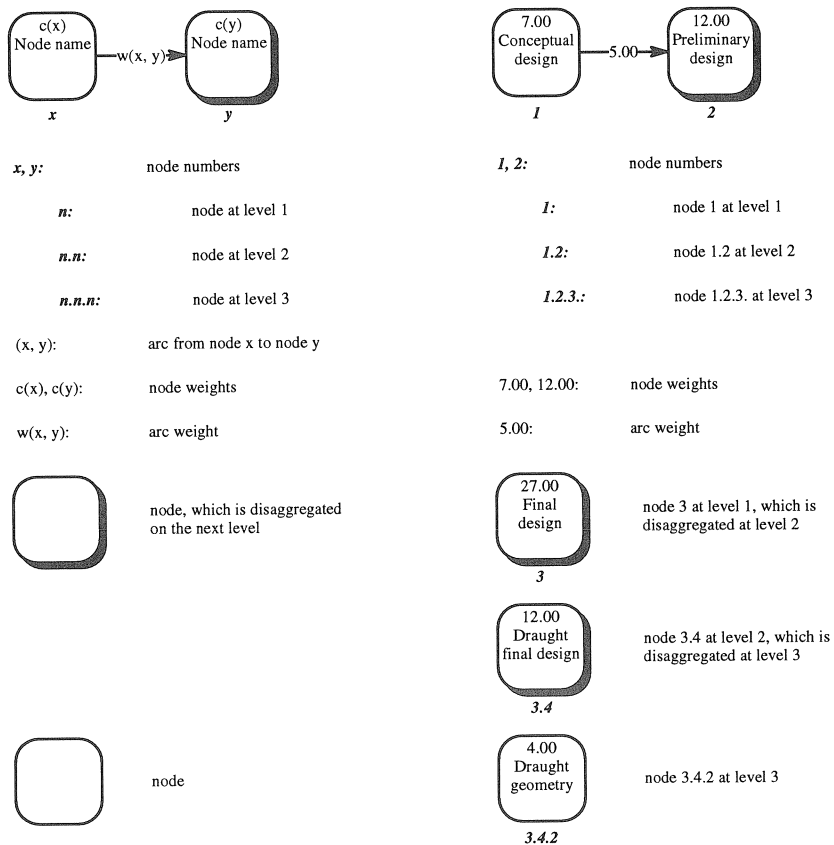

Fig. 4. Production digraph of Figure 3 according to the conventions used in this publication.

The second effect refers to modifications in the cost-relations between activities, e.g removal or addition of cost-relations. This is modelled as elimination or addition of arcs in the production digraph. Neither the set of nodes nor the node-weights are affected by this kind of effects. However, both the set of arcs and the arc-weights must be re-adjusted to the new situation.

The third effect refers to the separation of activities of the process into two or more separate activities. This involves complicated effects on the production digraph. Updates of both the set V of the nodes and the set E of arcs may be required. Often this means that the weighting functions c and w (the node-weights and the arc-weights) have to be modified as well.



Conventions

Examples

Fig. 5. Conventions for representation of production digraphs, used in this publication.

The fourth effect refers to changes due to the combination of several activities to one activity. This is modelled as effects on the production digraph, which are similar to those needed for splitting activities into two or more separate activities. The set V of nodes, the set E of arcs, and the weighing functions c and w have to be modified.

The fifth effect refers to changes in activities in the process, resulting from the deletion of an existing activity or the addition of a new activity. This also involves complicated effects on the production digraph. The change requires modification of the set V of nodes, the set E of arcs, and the weighing functions c and w as well. An example of such effect can be determined by comparing Figures 2 and 3. Figures 4 and 5 show the representation of production digraphs, as will be used in the remainder of this thesis.

3.3 *Cost accounting methods*

Cost accounting methods are briefly discussed here, since the production digraph model is used for analysis of cost-effects. Two classes of cost accounting methods are of particular interest to modelling costs using production digraphs. Boons et al. (1991) refer to them as Product Based Costing (PBC) and Activity Based Costing (ABC). They differ with respect to the assignment of costs to cost-objects, in particular the indirect (conversion) costs.

Chandansingh (1995) argues that ABC (see Cooper, 1988a–c, 1989) is appropriate for proper analyses of effects of information commodities on production costs. ABC provides accurate costs since it traces costs or allocates costs as good as possible (based on causal relations) to products or cost-objects. Hence it draws attention to incremental costs, focusing in particular on the causes of costs.

Furthermore, ABC is complementary to the production digraph model, since both use activities as basic element. The starting point is the definition of the major activities in a production process. Based on these activities, ABC lays out the cost-structure of a production process, which can be modelled effectively with the production digraph. Value-added and non-value-added activities (see Porter, 1985) can be identified, which may lead to improvement in the efficiency of the production process. Together they provide a sound basis for analyses and managerial decision-making concerning the use of information commodities in production processes.

4 **Case 1**

4.1 *Engineering consultant's profile*

Case 1 concerns one of the five branch-offices of an engineering consultant, in this chapter referred to as engineering consultant 2 (see profile in Table 2). The engineering consultant has been in business for more than 22 years, while the branch-office has 16 years experience in designing structures, mainly in the Netherlands. It is specialized in the design of concrete structures and in the detailing of prefab structural elements, on a commission basis for producers in the prefabricated concrete construction industry.

Table 2. Profile of engineering consultant 2.

CASE 1: ENGINEERING CONSULTANT 2	
Number of employees	28
Engineering consultants	3
Structural engineers	4
Structural engineers-draughtsmen	12
Draughtsmen	7
Administrative personnel	2

4.2 Classification of CAD systems

Table 1 describes the specific elements of the value adding dimensions of CAD systems which were identified through interviews with 4 draughtsmen. Currently, two CAD systems are used at the engineering consultant. The first, referred to as CAD system B1, supports production of drawings in general. The second, referred to as CAD system B2, supports the detailing of prefabricated structural elements in particular. CAD system B2 is based on CAD system B1, but is extended with routines and libraries for prefabricated structural elements.

4.3 Production digraphs of structural design

The case-study at engineering consultants 2 revealed 3 project-categories with respect to activities in structural design. These categories are:

1. detailing of prefabricated structures & elements (for office-buildings),
2. structural design and detailing of concrete office-buildings,
3. structural design of other (e.g. industrial and civil) structures.

Table 3 shows the importance of the three categories for the engineering consultant. The analyses of cost-effects of CAD systems will focus on category 1, since it accounts for approximately 50% of the annual turnover.

Table 3. Project-categories of engineering consultant 2.

CASE 1: ENGINEERING CONSULTANT 2		
Project-category		Share in turnover
1	Detailing of prefabricated structures & elements (for office-buildings)	50%
2	Structural design and detailing of concrete office-buildings	25%
3	Structural design of other (e.g. industrial and civil) structures	25%

Table 4. Production digraphs for engineering consultants 2.

Production digraph number	Project-category	Use of CAD system	Figure number
B0	1. Detailing of prefabricated structures & elements (for buildings)	No use	6
B1		CAD system B1	7
B2		CAD system B2	8

An overview of production digraphs constructed in this case-study is presented in Table 4. Production digraph B0 represents the initial production digraph for project-category 1, in which CAD systems are not deployed. The initial production digraphs are used to determine the effects of CAD systems B1 and B2. The alternative production digraphs are presented by production digraphs B1 and B2; the first results from deployment of CAD system B1, the latter from CAD system B2.

The structure of the production digraphs is based on an initial model, derived from literature. It was modified, since the design and detailing is based on an existing design or a predefined design-concept. The main activities, relations, and arc-weights (cost-relations) were reviewed and modified by the managers, structural engineers, and draughtsmen.

The node-weights (activity costs) are based on analyses of two cost-evaluations. The calculated node-weights were checked and modified, because:

1. activities in the cost-evaluations did not match with those of the graph,
2. features of some selected projects disturbed the activity-costs.

Draughting activities were analyzed in detail, during interviews with draughtsmen, since it was expected that they were affected by the use of the CAD systems. Node-weights were estimated by two draughtsmen. Averages of these estimates were used as node-weights of the draughting-activities. A similar procedure was followed to determine the effects of CAD systems (see production digraphs B1-B2).

4.4 Analysis of effects

4.4.1 Descriptive

Comparing the production digraphs B0 and B1 on the highest level of aggregation (level 1) reveals no structural changes. One effect which can be determined is the reduction in the node-weight $c(2)$. In addition, the arc-weight $w(2, sink)$ is reduced as well as a result of the reduction in node-weight $c(2)$. This arc-weight, representing the total project-costs, shows a reduction of 25,80%. This implies that use of CAD system B1 reduces the process-costs with 25,80%.

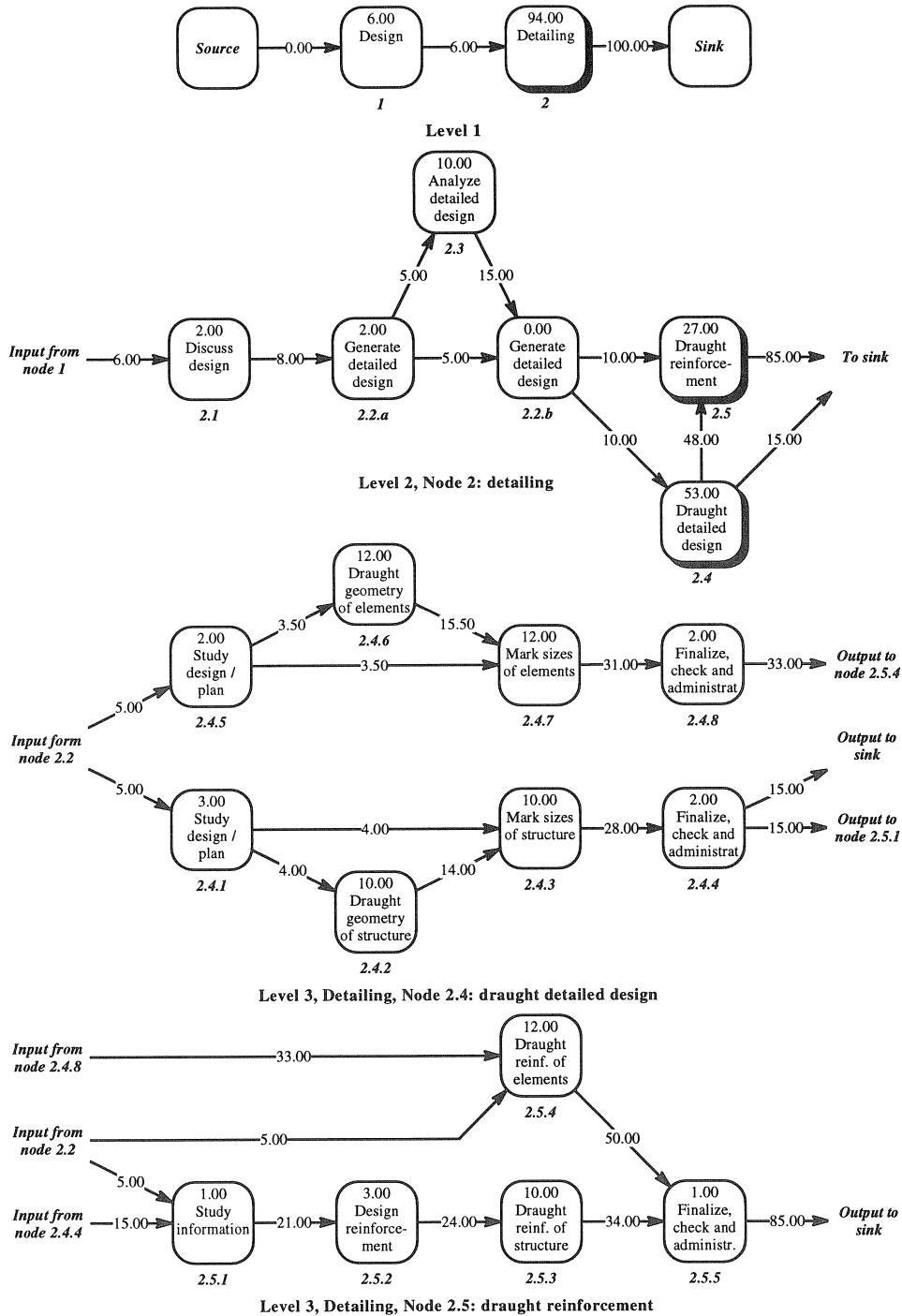

Fig. 6. Production digraph B0.

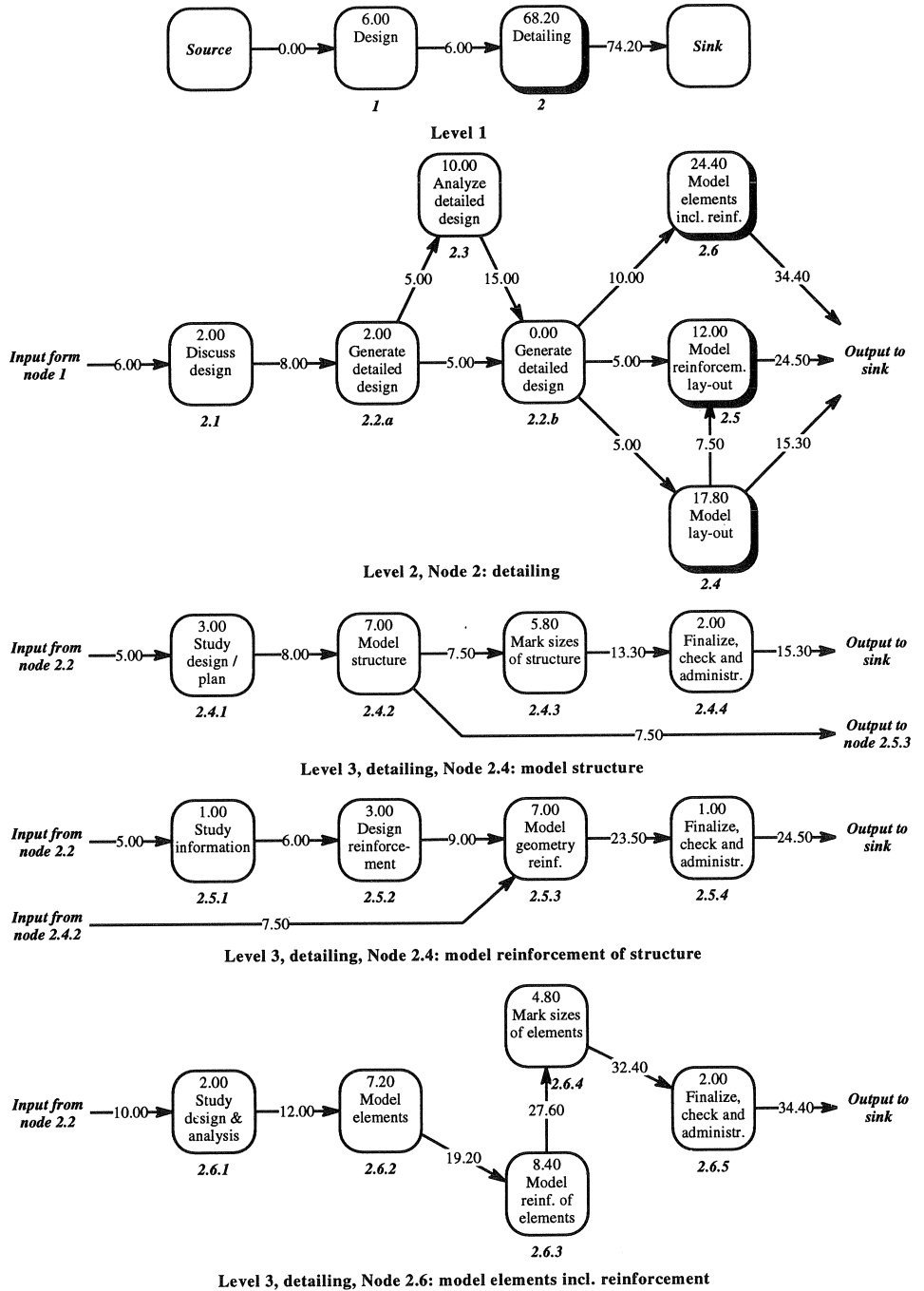

Fig. 7. Production digraph B1.

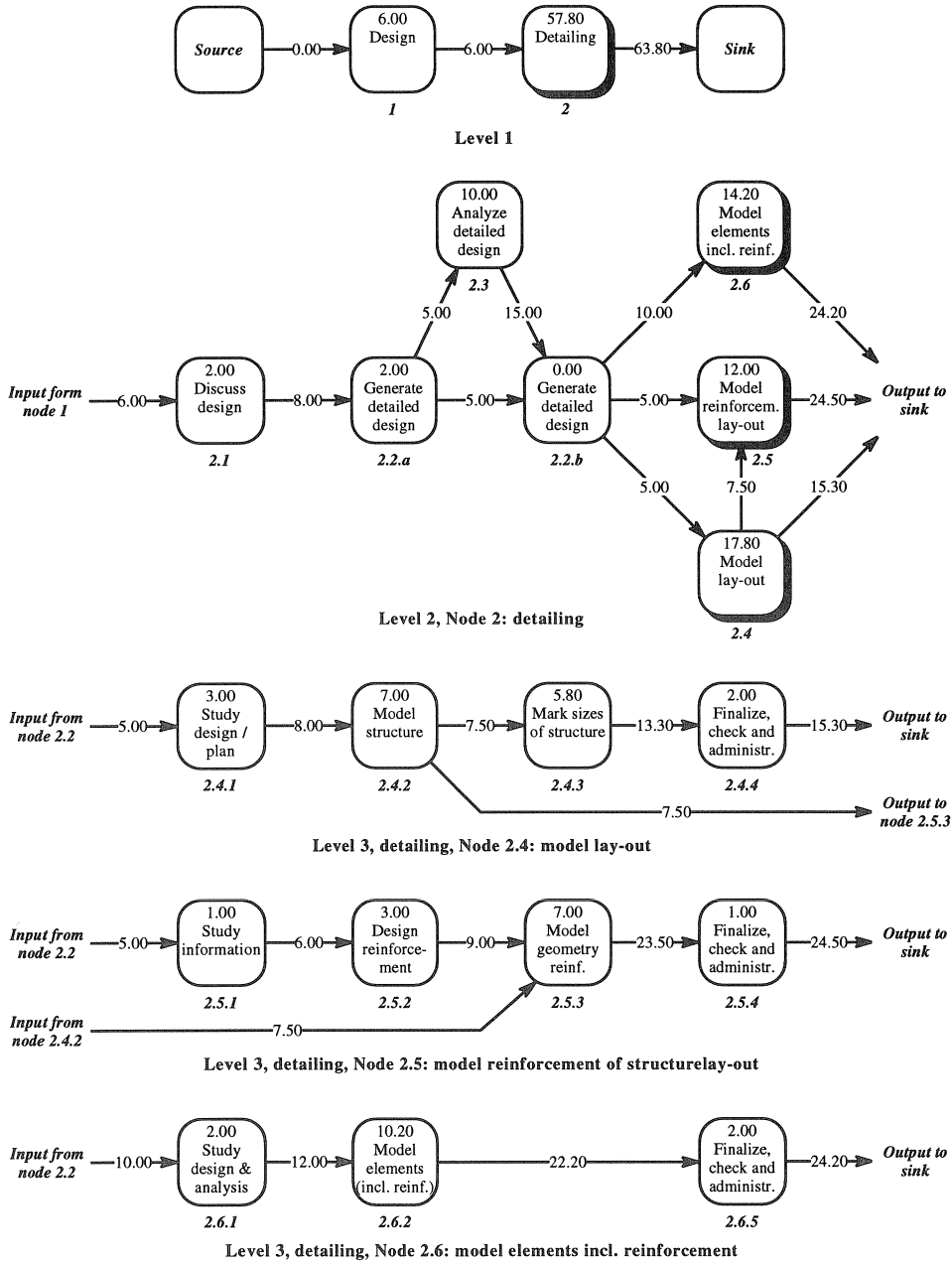

Fig. 8. Production digraph B2.

Considering node 2 at level 2 shows the addition of a new node (2.6), resulting from rather complex structural changes. Both node 2.4 and nodes 2.5 of production digraph B0 are split into two parts, resulting into 2.4.x, 2.4.y, 2.5.x and 2.5.y. The parts 2.4.y and 2.5.y are combined to one node. This node is substituted by node 2.6 in production digraph B1. The parts 2.4.x. and 2.5.x are substituted by nodes 2.4 and 2.5 of production digraph B1.

As a result of the substitutions, arcs are added to connect node 2.2 with node 2.6, and node 2.6 to the sink. The substitutions also result into reductions of the node-weights. The sum of the node-weights of nodes 2.4-2.6 of production digraph B1 are lower than the sum of the node-weights of nodes 2.4-2.5 of production digraph B0.

The complex structural changes referred to above are shown clearer at level 3. It is shown that within node 2.4 the (sub-)nodes 2.4.1-2.4.4 are removed, and within node 2.5 the node 2.5.4. These (sub-)nodes are combined and replaced by the nodes 2.6.1-2.6.5. The modelling of elements (including reinforcement) is integrated, and separated from the modelling of the remaining parts of the structure. Modelling of reinforcement is now done just after the modelling of the elements. Furthermore the arc between 2.6.1 and 2.6.4 is removed, since node 2.6.4 does not need an input from node 2.6.1.

With the use of CAD system B1 the modelling is done more efficient. The sum of the node-weights of nodes 2.6.1-2.6.5 of production digraph B1 are lower than the sum of the node-weights of nodes 2.4.5-2.4.8 and 2.5.4 of production digraph B0.

Other structural changes are substitutions of nodes 2.4.2 and 2.5.3. Together with the substitution an arc is added to connect these two nodes, since node 2.5.3 requires input from node 2.4.2. In addition the arc between nodes 2.4.1 and 2.4.3 is removed, since node 2.4.3 no longer requires input from node 2.4.1.

Node-weights are reduced as a result of the substitutions, since activities are performed more efficient, using CAD system B1. Production digraph B1 shows reductions for node-weights $c(2.4.2)$, $c(2.4.3)$, and $c(2.5.3)$. These changes result in changes in the subsequent arc-weights as well.

Comparing production digraphs B0, B1, and B2 shows that effects of CAD system B2 are quite similar to those of CAD system B1, except for the additional effects on node 2.6. Level 3 of production digraph B2 shows that nodes 2.6.2-2.6.4 are combined to one new node 2.6.2, as a result of the use of CAD system B2. At the same time the node-weight is reduced substantially. Resulting from this increase in efficiency the overall project-costs are reduced with an additional 10,20% to a total of 36,00%.

4.4.2 Effects attributed to CAD systems

In Tables 5 and 6 the effects are attributed to the specific elements of the value adding dimensions of the CAD system software. The effects on aggregation level 3 are considered, since they are the most detailed. Tables 5 and 6 also provide the total cost-reductions, based on the average of estimates

provided by draughtsmen. In addition an interval is provided for the cost-reductions. It is based on the minimum and maximum values of the estimates provided by the draughtsmen.

Table 5. Cost-effects related to elements of value adding dimensions of CAD system B1.

Node-number	Cost-effects	Elements of value adding dimensions ¹	Remarks
2.4.2	- 3,00%	1, 5, 6, 7, 9	Modelling must be accurate to account for the precise sizes.
2.4.3	- 4,20%	2	Sizes are derived by the CAD system from the model.
2.6.2 (for 2.4.6)	- 4,80%	1, 5, 6, 7, 9, 11	Efficient modelling of elements due to edit-features.
2.6.3 (for 2.5.4)	- 3,60%	1, 5, 6, 7, 9, 11, 8	Use of model of elements and the graphical symbols for (model elements) reinforcement.
2.6.4 (for 2.4.7)	- 7,20%	2	Sizes are derived by the CAD system from the model.
2.5.3	- 3,00%	1, 5, 6, 7, 9, 8	Use of model of structure and the graphical symbols for (model structure) reinforcement.
Total	- 25,80%		Interval: 24,40%–38,40%

¹ Numbers refer to the elements of the value adding dimensions in Table 1.

Table 6. Cost-effects related to elements of value adding dimensions of CAD system B2.

Node-number	Cost-effects	Elements of value adding dimensions ¹	Remarks
2.4.2	- 3,00%	1, 5, 6, 7, 9	Modelling must be accurate to account for the precise sizes.
2.4.3	- 4,20%	2	Sizes are derived by the CAD system from the model.
2.6.2 (for 2.4.6, 2.5.4, and 2.4.7)	- 25,80%	1, 2, 5, 6, 10, 11, 12	Efficient modelling of elements due to predefined model of prefabricated elements.
2.5.3	- 3,00%	1, 5, 6, 7, 9, 8	Use of model of structure and the graphical symbols for (model structure) reinforcement.
Total	- 36,00%		Interval: 29,60%–46,40%

¹ Numbers refer to the elements of the value adding dimensions in Table 1.

4.5 Conclusion

This case-study proves that the cost-effects of CAD systems on structural design processes can be determined, using the production digraph model. The analysis reveals not only the cost-effects, but attribute them to the specific elements of value adding dimensions of CAD systems. In addition this case-study clearly shows that the effects depends on the characteristics of the process as well.

CAD systems

CAD system B1 reduces project-costs because graphical modelling is done more efficiently than draughting. Efficient modelling is due to:

1. procedural information, furnished by the CAD systems, such as:
 - a. routines and procedures for input, edit, and output of graphical entities,
 - b. routines for computing of sizes of the structure, based on the graphical model;
2. declarative information in the form of:
 - a. graphical information in the project-files (e.g. drawing-files, files of previous projects).
 - b. graphical symbols of standard construction elements and reinforcement.

In addition to the reasons just mentioned CAD system B2 reduces project-costs, since it makes good use of the uniformity of the prefabricated structural elements. Generic models of these elements are predefined, which are used to model the elements through input of values for a limited set of parameters. This way of design (detailing) is often referred to as "parametric design", and is possible only for rationalized and standardized products.

Comparison of production digraphs B1 and B2 clearly indicates that better cost-effects can be achieved by using more sophisticated CAD systems. Sophistication refers to functional rather than technological sophistication. CAD system B2 is more sophisticated (tailored for this specific purpose) than CAD system B1. Use of CAD system B2 results an additional cost-reduction of 10,20% over use of CAD system B1.

Throughout this section the average cost-reductions are discussed. Comparison of these averages with the intervals for cost-reductions provided in Tables 5 and 6 shows that they are not very accurate. In all cases the interval for cost-reductions is large. However, the order of magnitude of cost-reductions is well represented by the average cost-reduction.

The cost-reductions determined in this case-study can be used to determine upper-bounds for the demand value of the deployment of CAD systems. These upper-bounds can be interpreted as an estimate of the maximum amount of money the engineering consultants might be willing to invest in the deployment of these systems. This amount should be compared to all costs involved in the deployment of CAD systems, such as costs for purchase of the system, training of draughtsmen, maintenance of the system, management, system-control, etc.

Upper-bounds for the demand value of CAD systems can be determined in monetary terms as:

$$\delta_x = \sum_{y=1}^n \alpha_{x,y} \beta_y \Delta$$

with: δ_x = upper-bound for the demand value of CAD system x (in Dfl. per annum),
 $\alpha_{x,y}$ = reduction of project-costs for project-category y , resulting from the deployment of CAD system x (in %),
 β_y = share of project-category y in the annual turnover (in %),
 Δ = annual turnover (Dfl. 3.300.000,-),
 n = number of project-categories.

Chandansingh (1995) describes the effects of the CAD systems on the other project-categories. The following values for $\alpha_{x,y}$ and β_y were determined:

	Project-category 1	Project-category 2	Project-category 3
β_y	50%	25%	25%
$\alpha_{x,y}$			
CAD system B1	25,80%	13,80%	13,80%
CAD system B2	36,00%	13,80%	13,80%

The values can be used to determine the upper-bounds for the demand value of CAD systems for engineering consultant 2:

$$\delta_{\text{CAD system B1}} = \{0,258 * 0,50 + 0,138 * 0,25 + 0,138 * 0,25\} * 3.300.000 = \text{Dfl. } 653.400,-$$

$$\delta_{\text{CAD system B2}} = \{0,360 * 0,50 + 0,138 * 0,25 + 0,138 * 0,25\} * 3.300.000 = \text{Dfl. } 821.700,-$$

5 Case 2

5.1 Reinforcement-subcontractor's profile

Case 2 concerns a division of an organization. This division is involved in the production, transport and fixing of reinforcement bars (so-called rebars). It represents one of the six largest reinforcement-subcontractors (RS) in the Netherlands specialized in cutting and bending of rebars in factories.

This research focused primarily on the production and transport of rebars. Table 7 stretches the current production and transport of rebars within the division. Staff-members involved in this process are listed in this table. In addition, costs incurred by the production of bar-bending-schedules, scheduling production of rebars, production of rebars, and transport of rebars are provided. The remainder of this case-description deals with (costs of) production of bar-bending-schedules.

Table 7. Profile of division production & transport of rebars.

DIVISION: PRODUCTION & TRANSPORT OF REBARS		
<i>Number of employees</i>		32
Managing director / manager		2
Bar-bending-schedulers		3
Production-schedulers		4
Shop-floor-employees		21
Administrative personnel		2
<i>Annual turnover (Dfl.)</i>		2.520.000,-
Costtype	Percentage of turnover	Amount (Dfl.)
Production of bar-bending-schedules	12.5%	315.000,-
Scheduling production of rebars	12.5%	315.000,-
Production of rebars (cut, bend, etc.)	65.0%	1.638.000,-
Transport rebars to site	10.0%	252.000,-

Interviews revealed that the production of bar-bending-schedules is affected by the so-called WUF-diskette, a product of the use of CAD systems in structural design. It is the first activity in the production of rebars, where information provided by structural design is processed. Other activities may be affected as well, but that depends on information processing in this activity. The cost-effects of CAD systems on production can be analyzed through analysis of the cost-effects of the different possible deployments of the WUF-diskette in the production of bar-bending-schedules.

5.2 Classification of information commodities

Information commodities used for the production of bar-bending-schedules are reinforcement-drawings. Traditionally these drawings, the output of the structural design process, serve as input for realization of reinforcement in construction. The reinforcement is represented schematically on drawings, according to national or international conventions which are prescribed in design-codes.

For a long time CAD systems did not change this situation, since the output of the structural design remained the reinforcement-drawings. However, CAD systems are used not only to produce reinforcement-drawings, but to determine the properties and sizes of rebars as well. Recently a reinforcement-exchange-format, called WUF, was developed in the Netherlands. This format enables the exchange of declarative information of rebars on diskette from CAD systems to the CAM system of the RS. This information is converted by the RS and imported into its CAM system.

Table 8. Value adding dimensions of drawings and the WUF-diskette.

Value Adding Dimensions	Reinforcement drawings	WUF-diskette
Kernel		
– procedural information (routines for:)		
– declarative information (libraries with:)	<ol style="list-style-type: none"> 1. Shape of rebars. 2. Location of rebars. 3. Concrete cover on rebars. 4. Sizes of the concrete structure. 	<ol style="list-style-type: none"> 1. Shape of rebars. 2. Properties and sizes of rebars. 3. Number of rebars.
Storage	5. Paper / calque	4. Diskette, according to WUF
Processing		
Distribution		
Presentation	6. Symbolic representation, according to design code: (NEN 3870).	

The WUF-diskette is still in an experimental phase. It can be deployed in several different ways, which depend on organizational conditions. Conditions concerning responsibilities alter the use of the WUF-diskette at the reinforcement-subcontractor. Also, agreements on what to include in the WUF-diskette determine the way it is used. Presently, the WUF-diskette is used together with drawings, that differ from traditional reinforcement-drawings. On the drawings – related to the WUF-diskette – the rebars are labelled, in contrast to unlabelled rebars on traditional drawings. These labels (bar-codes) are used to identify rebars and to find the relevant information on the WUF-diskette.

The effects of this information commodity – termed the WUF-diskette – on the production of bar-bending-schedules were analyzed. The effects are determined by comparing the traditional situation (using drawings only) with the new situation in which the WUF-diskette is used. Table 8 lists the elements of the value adding dimensions of the traditional reinforcement-drawings and the WUF-diskette.

5.3 Production digraphs

The production digraphs for the process of production of bar-bending-schedules are based on direct observations. The main activities had to be determined from observations, since previous analyses of the production of bar-bending-schedules were rather poor. The activities are performed in a sequential order; cost-relations between the activities can be identified easily.

The activity costs (node-weights) are based on measurements taken during the observations and during the experiments. The time needed for each activity was measured. These measurements were used to determine the costs of each activity. It is assumed that the only relevant costs are labour-costs, and that time is a proxy for costs.

Material-costs are not included in these analysis, for two reasons. First, the production of bar-bending-schedules is considered. In this process material is not handled, so material-costs are not relevant. Second, previous experiments showed that use of the WUF-diskette hardly affects the quantity of the material. Based on this experiment it is expected that the material-costs will not be affected.

The effects of three different deployments of the WUF-diskette were considered in this case-study:

1. WUF-diskette^{alt1}: deployment of the WUF-diskette, requiring checking of the rebars at the RS,
2. WUF-diskette^{alt2}: deployment of the WUF-diskette, requiring neither checking of the rebars nor determination and processing of additional rebars at the RS.
2. WUF-diskette^{alt3}: deployment of the WUF-diskette, requiring both checking of the rebars and determination and processing of additional rebars at the RS,

Table 9. Production digraphs for the production of bar-bending-schedules.

Production digraph number	Description	Deployment of WUF-diskette	Figure number
D0	1. Simple reinforcement:	No deployment	9
D1	top reinforcement of a slab	WUF-diskette ^{alt1}	10
D2		WUF-diskette ^{alt2}	11
D3		WUF-diskette ^{alt3}	12

Table 9 provides an overview of the production digraphs constructed in this case-study. An initial production digraph was constructed: production digraph D0 for simple reinforcement without deployment of the WUF-diskette. This production digraph is used to analyze the effects of the different deployments of the WUF-diskette. Production digraph D1 shows the effects of deployment WUF-diskette^{alt1} on production digraph D0, while production digraph D2 shows the effects of deployment WUF-diskette^{alt2}.

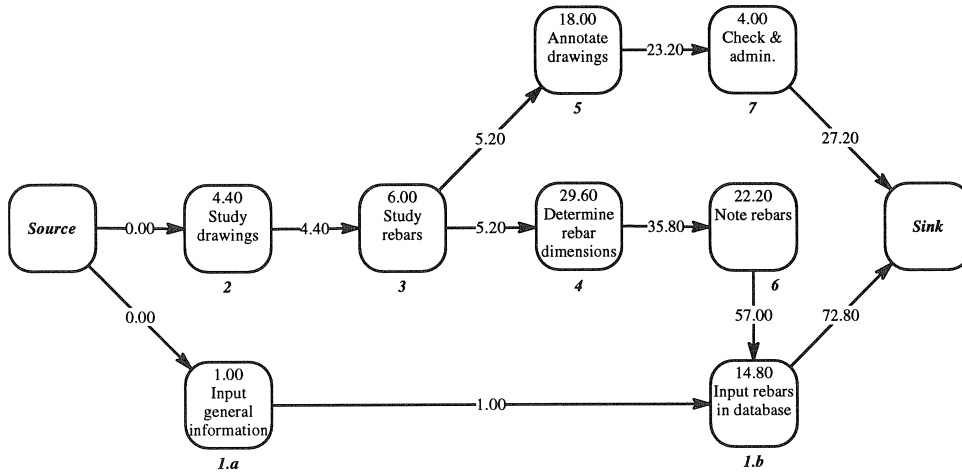

Fig. 9. Production digraph D0.

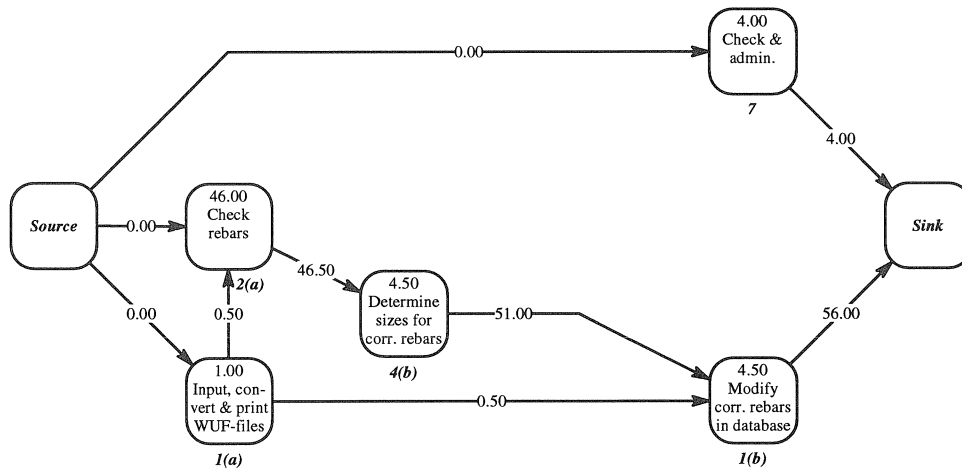

Fig. 10. Production digraph D1.

5.4 Analysis of effects

5.4.1 Descriptive analysis

Effects of WUF-diskette^{alt1} can be determined by comparing the production digraphs D0 and D1. Nodes 2, 3, 4, 5, and 6 of production digraph D0 are deleted, since these activities are no longer required. Nodes 2(a) ("check rebars") and 4(b) ("determine sizes for corrected rebars") are added in D1, since this deployment of the WUF-diskette requires checking of rebars. Node 1(a) ("input general

information”) is substituted by a new node 1(a) (“input, convert & print WUF-files”). In addition, node 1(b) (“input rebars in database”) is replaced by a new node 1(b) (“modify corrected rebars in database”). Node 1(a) has output to both node 2(a) and node 1(b), while node 1(b) requires input from node 4(b) as well.

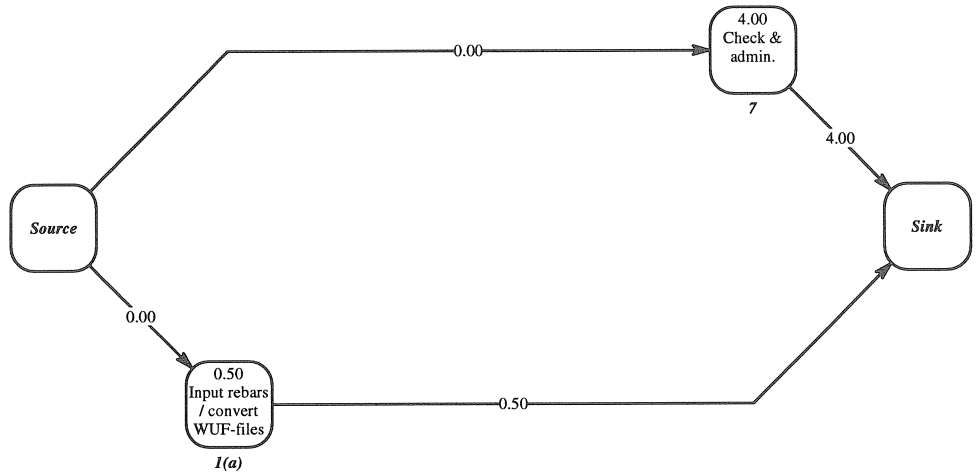

Fig. 11. Production digraph D2.

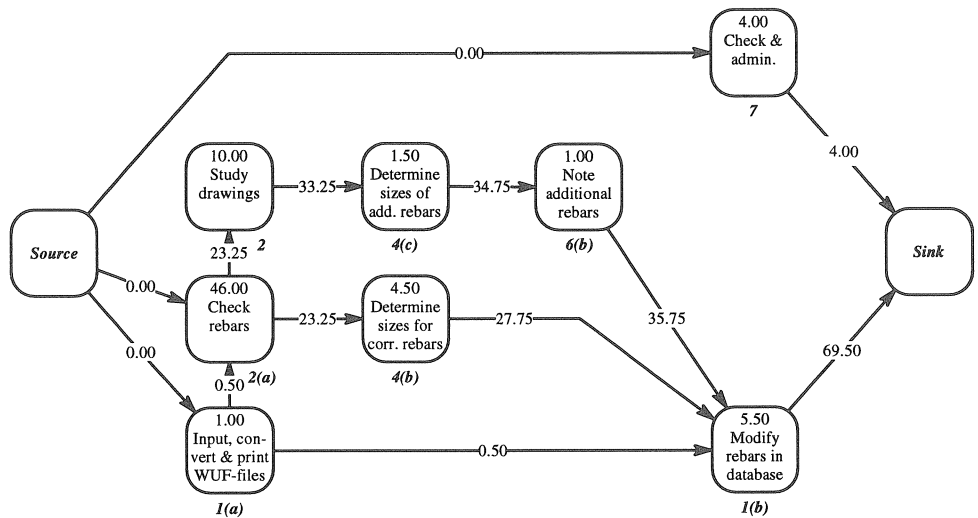

Fig. 12. Production digraph D3.

Costs are reduced, since node-weights $c(2)$, $c(3)$, $c(4)$, $c(5)$, and $c(6)$ do not appear in production digraph D1. In addition node-weight $c(1(b))$ is lowered substantially, since only a limited number of rebars need to be modified. The overall costs are still lowered despite the high node-weights $c(2(a))$ and $c(4(b))$. In particular node-weights $c(2(a))$ indicates that still substantial costs are involved in this deployment of the WUF-diskette. That is why the overall cost-reduction is only 40,00%.

Effects of WUF-diskette^{alt2} for simple reinforcement can be determined by comparing the production digraphs D0 and D2. It can be seen that nodes 2, 3, 4, 5, and 6 of production digraph D0 are deleted. Node 1(a) ("input general information") is substituted by a new node 1(a) ("input & convert WUF-files"). Costs are reduced dramatically, since node-weights $c(2)$, $c(3)$, $c(4)$, $c(5)$, and $c(6)$ do not appear in production digraph D2. The overall cost-reductions, resulting from this deployment of the WUF-diskette increases up to 95,50%.

5.4.2 Predictive analysis

The production digraphs provide possibilities for predictive analysis of the different deployments of the WUF-diskette. In the case-study, the effects of the deployment of the WUF-diskette, requiring both checking of the rebars, and determination and processing of additional rebars at the RS was not considered. However, with the insight gained from the production digraphs the effects of this deployment, referred to as WUF-diskette^{alt3}, can be predicted.

Production digraph D3 represents the predictive analysis of the effects of WUF-diskette^{alt3}. In addition to the changes already seen in production digraph D1, an arc is added between node 2(a) and node 2. Node 2(a) ("check rebars") provides input to node 2 ("study drawings"), enabling lowering of node-weight $c(2)$. The node-weights used in production digraph D3 are estimates based on the other production digraphs. Comparison with production digraph D0 shows that WUF-diskette^{alt3} results in cost-reduction of 26,50%.

5.5 Conclusion

The production digraph model illustrates the cost-effects of use of the WUF-diskette in a clear way. The production digraphs show that the different deployments of WUF-diskette have completely different cost-effects. The different deployments are determined by project-organization, arrangements concerning liabilities, etc., rather than on the WUF-diskette itself. This proves that the effects of an information commodity depends not only on its elements of the value adding dimensions, but on the mode of deployment as well.

The results show that the use of the WUF-diskette at the reinforcement-subcontractor can result in cost-reduction up to 95,00% of the production-costs of bar-bending-schedules. However, deployment WUF-diskette^{alt3} would yield much lower cost-reduction of approximately 26,50%. An intermediate cost-reduction of 40,00% can be achieved with the deployment WUF-diskette^{alt1}.

Cost-reductions, based on the experiments, matched very well with the estimates of the cost-reductions, provided by the bar-bending-schedulers. The cost-reductions can be used to determine upper-bounds for the demand value of the different deployments of the WUF-diskette. These upper-

bounds can be interpreted as an estimate of the maximum amount of money the reinforcement-sub-contractor might be willing to invest in the deployment. This amount should be compared to all costs involved in the deployment of the WUF-diskette, such as development-costs for additional features of the CAM system, maintenance of the system, management, system-control, etc. Upper-bounds for the demand value of CAD systems can be determined in monetary terms as:

$$\delta_x = \alpha_x \Delta$$

with: δ_x = upper-bound for the demand value of WUF-diskette deployment x (in Dfl. per annum),
 α_x = reduction of production-costs of bar-bending-schedules, resulting from WUF-diskette deployment x ,
 Δ = annual production-costs of bar-bending-schedules (Dfl. 315.000,-)

For simple reinforcement the values for α_x are summarized below:

Simple reinforcement	WUF-diskette ^{alt1}	WUF-diskette ^{alt2}	WUF-diskette ^{alt3}
α_x	40,00%	95,50%	26,50%

The values can be used to determine the upper-bounds for the demand value of the different WUF-diskette deployment for the reinforcement-subcontractor:

$$\delta_{\text{WUF-diskette alt1}} = 0,400 * 315.000 = \text{Dfl. } 126.000,-$$

$$\delta_{\text{WUF-diskette alt2}} = 0,955 * 315.000 = \text{Dfl. } 300.825,-$$

$$\delta_{\text{WUF-diskette alt3}} = 0,265 * 315.000 = \text{Dfl. } 83.475,-$$

6 Conclusions

6.1 Cost-effects of CAD systems

This research shows that cost-effects can be determined quantitatively. For a business-unit deploying a CAD system cost-reductions can be determined, which represent estimated upper-bounds for the demand value (or benefits) of the deployment of the system. The cost-reductions are determined as percentages of project-costs. With additional information concerning distribution of project-costs and annual turnover the cost-reduction can be expressed in monetary terms.

Cost-effects are determined and attributed to the specific elements of the value adding dimensions of CAD systems. This facilitates appropriate analysis of the different cost-effects of different CAD systems. Attributing cost-effects to the specific elements of value adding dimensions enables both descriptive and predictive analysis of cost-effects of these systems.

The specific elements of the value adding dimensions of CAD systems are important, but cost-effects are determined by their deployment. Different deployments of a specific CAD system may result in

different cost-effects. A specific deployment of a CAD system depends on process-characteristics, which are related to aspects as project-organization, rationalization of the process and product, liabilities, etc.

Resulting from deployment of CAD systems, reductions varying from 6,50% to 36,00% of the structural design costs have been found. The WUF-diskette can be seen as the result of the use of a specific CAD system in the structural design process. Deployment of the WUF-diskette results in reductions in the production-costs of bar-bending-schedules, which vary from 26,50% to 95,00%.

The cost-reductions are based on averages of estimates, provided by experienced staff-members within the organizations, and on measurements. However, they provide accurate estimates of the order of magnitude of the cost-effects of different CAD systems, since:

1. the intervals for cost-reductions were relatively small (see section 4.4.2),
2. the measurements during the experiments, and the estimates of the staff-members matched very well (see section 5.5).

6.2 *Modelling*

The research shows that the framework supports decision-making concerning investments in CAD systems, since it facilitates analysis of cost-effects of CAD systems on structural design and construction processes. Analyses with the production digraph model pinpoint effects and relate these to the value adding dimensions of CAD systems. The effects can hardly be illustrated better than with production digraphs, since changes in the structure of the process, the costs of activities, and the cost-relations are shown explicitly.

The case-studies proved that cost-effects are determined mainly by the deployment of CAD systems. One of the strong points of the production digraph model is that it facilitates analysis of the different deployments of a CAD system. Especially in the third case the modelling abilities with respect to the different deployments of an information commodity were demonstrated.

Critical for the reliability of the cost-effects is the determination of the relevant activities, the relevant activity-costs, and the cost-relations. The relevant activities and relations were determined partly from previous research and partly from observations during the case-studies. The activities were checked and modified with several employees and managers.

The application of this approach in the case-studies showed that the accuracy of the structural effects and the cost-reductions improve, when:

1. the relevant activities within the process are clear or relatively easy to determine; e.g. the activities in production of bar-bending-schedules (case-study 3) were clearer than the activities in structural design process (case-studies 1 and 2),
2. the relevant cost-information is based on both measurements, and estimates of staff-members; e.g. measurements and estimates in case-study 3 provided more accurate cost-information than the estimates in case-studies 1 and 2.

6.3 Generalization

The research supports the idea that the framework can be used to analyze cost-effects of any information commodity on any production process. In the case-studies two production processes were considered: the structural design process and (a part of) the construction process. In addition several (types of) information commodities were considered: CAD system, WUF-diskette, and reinforcement-drawings.

This conclusion is supported by related research as well. In particular, Bellin (1991) demonstrated the suitability of the approach to model the effects of CASE-tools on the software engineering process. Currently, the production digraph model is being used and extended to analyze the effects of information commodities based on artificial intelligence (AI).

References

- BELLIN, D. (1991) *Information commodities and the production process: how the introduction of CASE tools affects the software development life cycle*. PhD-Dissertation, The City University of New York.
- BETTS, M. (1992). How strategic is our use of information technology in the construction sector. *The international journal of construction information technology*, 1 (1), 79-97.
- BOONS, A. A. M., ROBERTS, H. J. E., & ROOZEN, F. A. (1991). *Activity based costing: strategisch cost management voor vernieuwende bedrijven*. Deventer, NL: Kluwer Bedrijwetenschappen.
- CHANDANSINGH, R. A., & VOS, C. J. (1991). IT-use in reinforced concrete detailing: the current state, a forecasting model, a future concept. In *CIB-W78 Seminar: The computer integrated future*. Eindhoven, The Netherlands
- CHANDANSINGH, R. A., & VOS, C. J. (1993a). Modelling the effects of CAD on concrete construction using production digraphs. *The international journal of construction information technology*, 1 (4), 39-50.
- CHANDANSINGH, R. A., & VOS, C. J. (1993b). Modelling the effects of Information Technology of Construction. In K. S. Mathur, M. P. Betts, & K. W. Tham (Eds.), *Management of information technology for construction* (pp. 559-570). Singapore: World Scientific Publishing Co. Pte. Ltd.
- CHANDANSINGH, R.A. (1995) *The Economic Value of CAD systems in Structural Design and Construction; a modelling approach*. PhD-Dissertation, Delft University of Technology.
- COOPER, R. (1988a). The rise of activity-based costing – Part One: What is an activity-based cost system. *Journal of cost management for the manufacturing industry* (Summer), 45-54.
- COOPER, R. (1988b). The rise of activity-based costing – Part Two: When do I need an activity-based cost system. *Journal of cost management for the manufacturing industry* (Autumn), 41-48.
- COOPER, R. (1988c). The rise of activity-based costing – Part Three: How many cost drivers do you need and how do you select them. *Journal of cost management for the manufacturing industry* (Winter), 34-46.
- COOPER, R. (1989). The rise of activity-based costing – Part Four: What do activity-based cost systems look like? *Journal of cost management for the manufacturing industry* (Spring), 38-49.
- HARARY, F. (1969). *Graph theory*. Reading, MA: Addison-Wesley.

- MOWSHOWITZ, A. (1992a). On the market value of information commodities: I. The nature of information and information commodities. *Journal of the American Society for Information Science*, 43 (3), 225–232.
- MOWSHOWITZ, A. (1992b). On the market value of information commodities: II. Supply price. *Journal of the American Society for Information Science*, 43 (3), 233–241.
- MOWSHOWITZ, A. (1992c). On the market value of information commodities: III. Demand price. *Journal of the American Society for Information Science*, 43 (3), 242–248.
- PORTER, M. E. (1985). *Competitive advantage; creating and sustaining superior performance*. New York: Free Press.
- TATUM, C. B. (1990). *Using CAE to improve construction planning, operations and quality* (No. 008). CIFE, Stanford.